

Load Class	A 15	B 125	C 250	D 400*
Minimum Dimensions (mm)	X 2-DIM.1	X-DIM.2	X-DIM.3	X-DIM.4
Maximum Dimensions (mm)	Y 2-DIM.1	Y-DIM.2	Y-DIM.3	Y-DIM.4
	Z 2-DIM.1	Z-DIM.2	Z-DIM.3	Z-DIM.4
	Y 2-DIM.1	Y-DIM.2	Y-DIM.3	Y-DIM.4
	Z 2-DIM.1	Z-DIM.2	Z-DIM.3	Z-DIM.4

\* e.g. parking areas for all types of road vehicle. Not suitable for carriageway of roads or industrial areas.

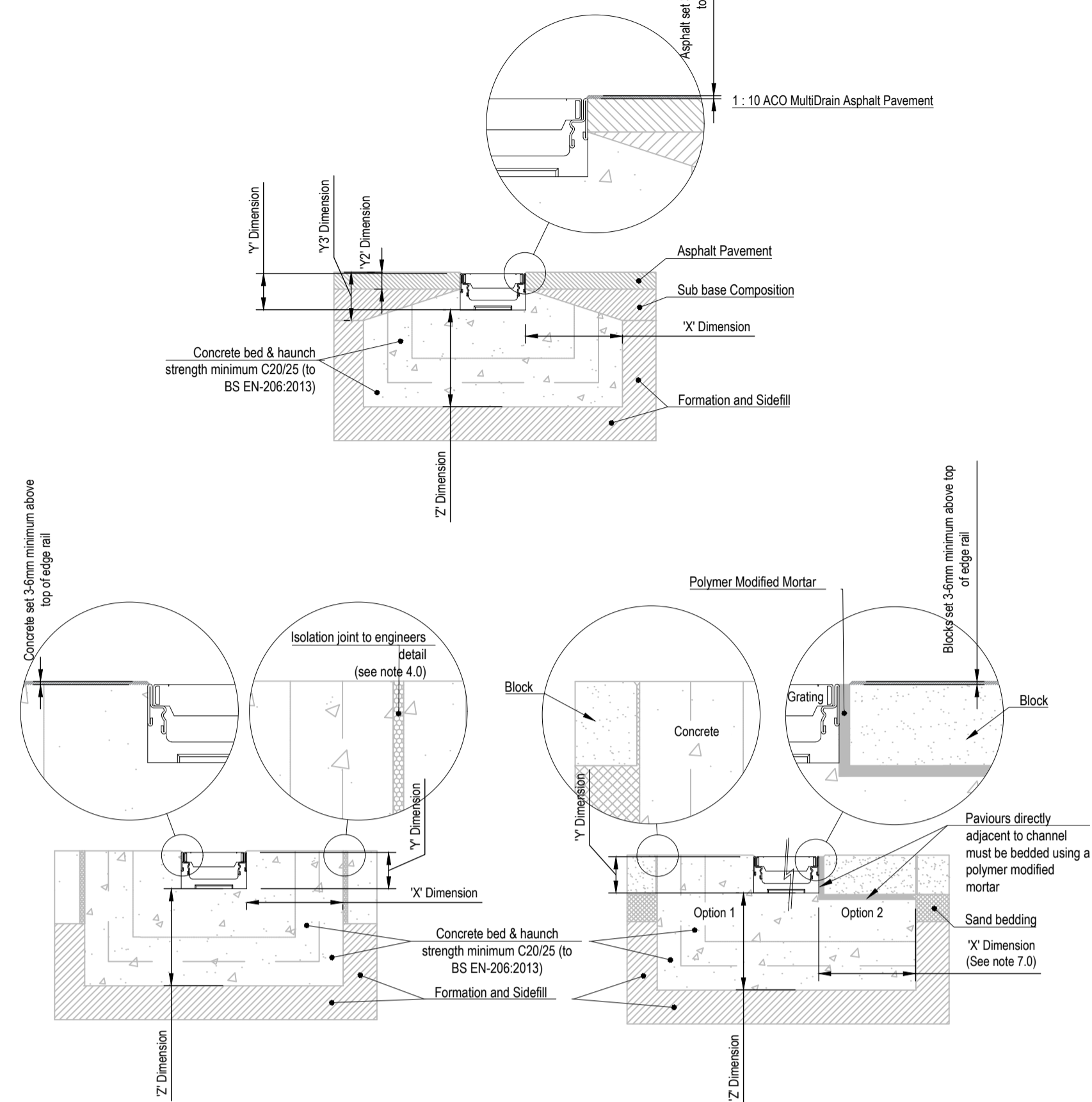

ACO MultiDrain Concrete Pavement SCALE 1:10

ACO MultiDrain Block Pavement (Option 1 and 2) SCALE 1:10

**NOTES**

- 1.0 Load Class**  
Installation recommendations shown are ACO minimum recommendations for BS EN 1433:2002 load class requirements.
- 2.0 Ground Conditions**  
The long term performance of a channel installation to sustain vertical and lateral loads depends upon A) ground conditions B) stability of the adjacent pavement and C) a durable concrete bed and surround. The recommended installation detail may require the minimum dimensions to be revised to achieve site specific load class requirements (referred to in 1.0 above).
- 3.0 Cutting and Joining**  
Mitre joints are formed by cutting the channels to the required angle and butting them together with appropriate sealant (e.g. Sikaflex 11FC or similar) or ACO Repair Kit. Where possible 90° joints and T's should be formed so that gratings do not have to be cut. Angles can be formed by connecting them using proprietary PVCu pipework attached to ACO inlet/outlet enclosures. For further details please contact ACO Design Services Team.  
**Note:** For Load Classes higher than C 250, mitred joints are not recommended in vehicular areas. Where requested ACO can custom manufacture angled junctions to order.
- 4.0 Isolation Joints**  
The channel must be isolated from the surrounding environment. An isolation joint must be positioned up to 1500mm from the channel wall. Any dowel bars must be located no nearer than 150mm from the channel wall. Other isolation joints in surrounding slab must be continued through the channel. Additional crack control may be required to comply with specifier requirements.
- 5.0 Installation into in-situ Slab**  
Where a channel is to be installed into an existing concrete slab it is necessary to cut a suitably sized pocket in the slab. The channel will then need to be bedded in polymer modified mortar of 25mm minimum thickness (this may vary depending on the type of mortar used). Engineering advice may be necessary.
- 6.0 Temporary Installation**  
A channel installation is not complete until the final surfacing is laid. In any temporary condition, i.e. with the channel walls projecting above adjacent ground, site traffic should not cross channels. Loose boards, stone fill or cover plates will not protect the channel walls or grating. A temporary channel crossing should be formed by raising the ground level locally, to 3 - 6mm above top of edge rail, either side of a channel for a distance of 750 to 1000mm, to form ramps. Note that the channel load class should be adequate to carry the site traffic.
- 7.0 Block Pavements**  
The channel must be supported laterally. Blocks laid directly against a channel must be laid as a solid course and restrained from movement by bedding securely on the concrete haunch e.g. by using a polymer modified mortar for bed and perpendicular joints (e.g. RONAFIX mortar mix C or similar). Blocks or slabs bedded on sand remote from the channel should be set at a higher level to compensate for possible settlement of the paving in service.
- 8.0 Grate Locking System**  
Gratings should be securely fixed to the channel, where required, using an appropriate grate lock system (where available).
- 9.0 Channel Protection**  
Avoid contact between compaction equipment and top of ACO channel edge rail. The installer must ensure that the finished surface level lies above the top of the edge rail (by at least 3-6mm). Covering or protecting the grating, before concreting the haunch or laying blocks, removes the time and cost associated with cleaning the channel and grating of cement material and embedded stones. (Please note that ACO channels must be installed with the grating in place to prevent deformation of the channel).
- 10.0 Watertight Installation to BS EN 1433:2002**  
Where ACO channel joints/tings and channel/pavement interfaces are to be sealed, an appropriate sealant should be used (e.g. Sikaflex 11FC or similar). Guidance on the necessary surface preparation and/or priming should be sought from the sealant manufacturer.

- For Guidance a typical method of application follows:
- The end faces of the channels are to be sound and free from dust, oil, and grease, with any loose material or dirt removed, e.g. by mechanical wire brush. No water drops should be evident.
  - Using a standard cartridge gun, apply the sealant evenly and with no flaws. The detail on the ends of a channel varies from one product to another.
  - Products with a basically flat face - apply the sealant in a layer approximately 5mm thick to one face of the joint.
  - Products with a sealing groove within the end face - apply the sealant in a bead of approximately 10mm diameter into the sealing groove.
  - Products with a sealing groove following the inside shape of the channel - apply the sealant to the end face of the channel and to the sealing groove, such that when the joint is completed, the sealant will both cover the end face and fill the groove.
  - The channel unit should be placed on the prepared concrete bedding and pressed against the previously placed channel unit. A sealed joint of approximately 1-2mm width should be formed between adjacent channel units.
  - Excess sealant should be wiped from the inside face of the channel to leave a smooth finish.
  - The sealant is to be left to cure for 24 hours, during which time the sealant should be kept as dry as possible.

**Note:** Galvanised steel and iron products have good corrosion resistance to concrete and mortar products but may experience corrosion if high chloride and/or sulphate content is present. Use only good quality concrete and consider using corrosion inhibitors where necessary. The use of protective coatings, such as paint, can minimise the risk of corrosion.

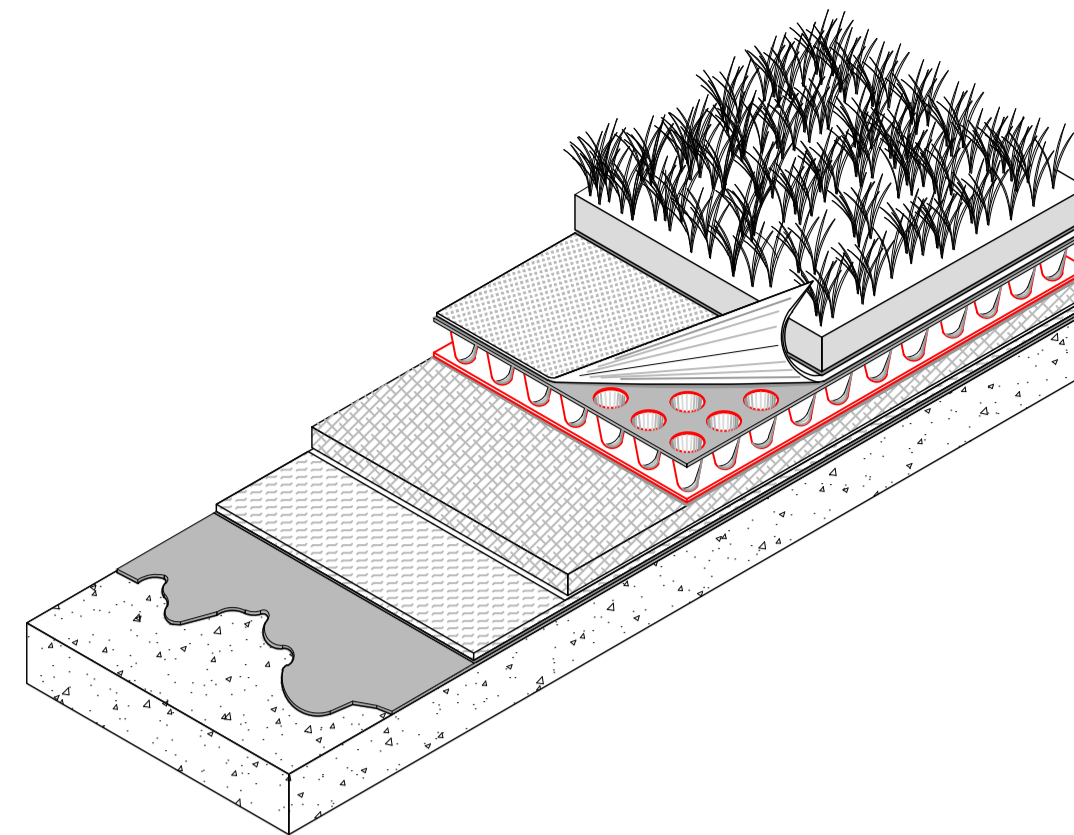

GREEN ROOF SCHEMATIC SCALE NTS

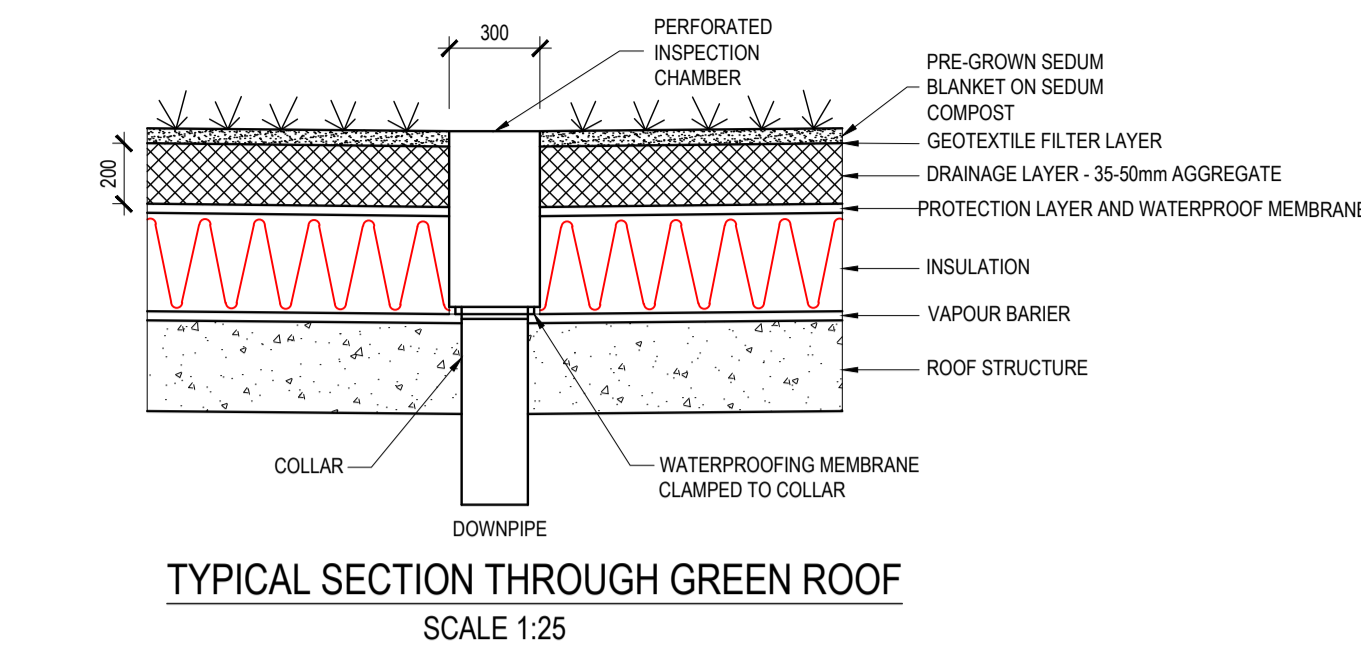

TYPICAL SECTION THROUGH GREEN ROOF SCALE 1:25

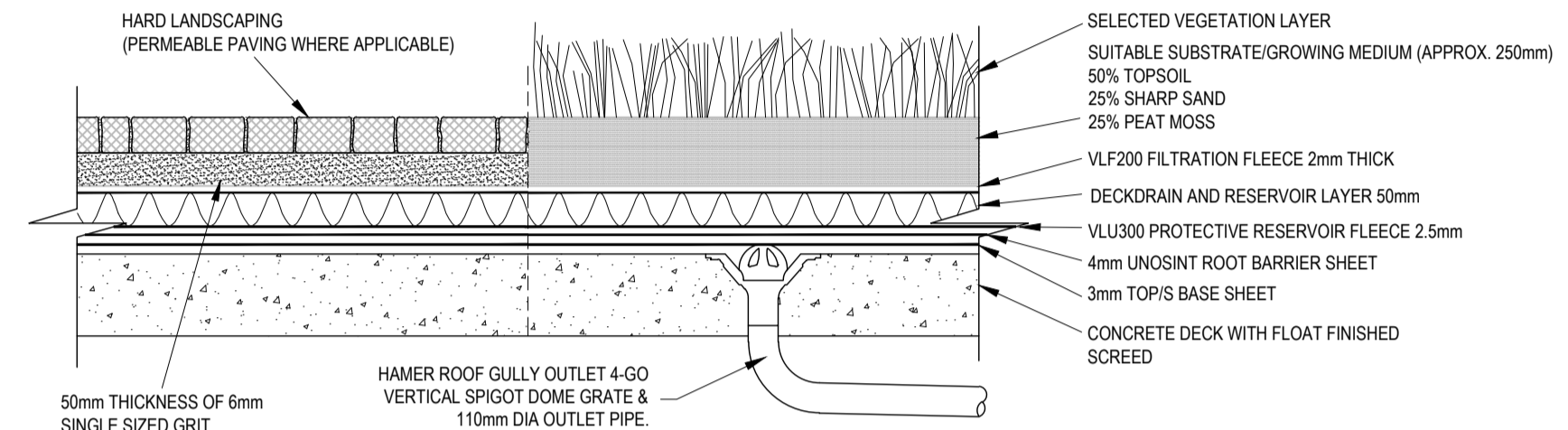

PODIUM DECK DETAIL SCALE NTS

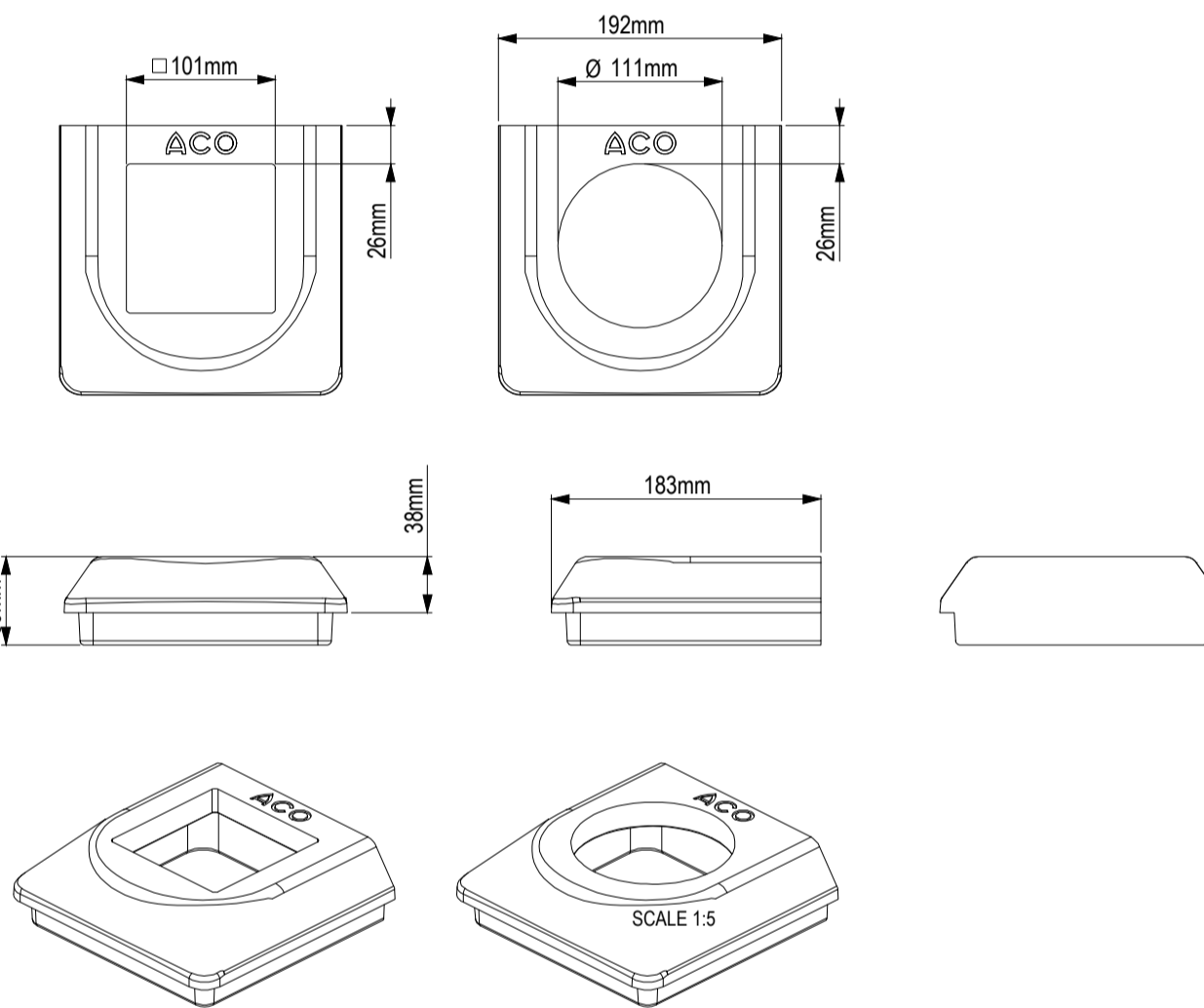

DOWNPIPE CONNECTOR, M150D / M150PPD 110mm DIAMETER, 100mm SQUARE

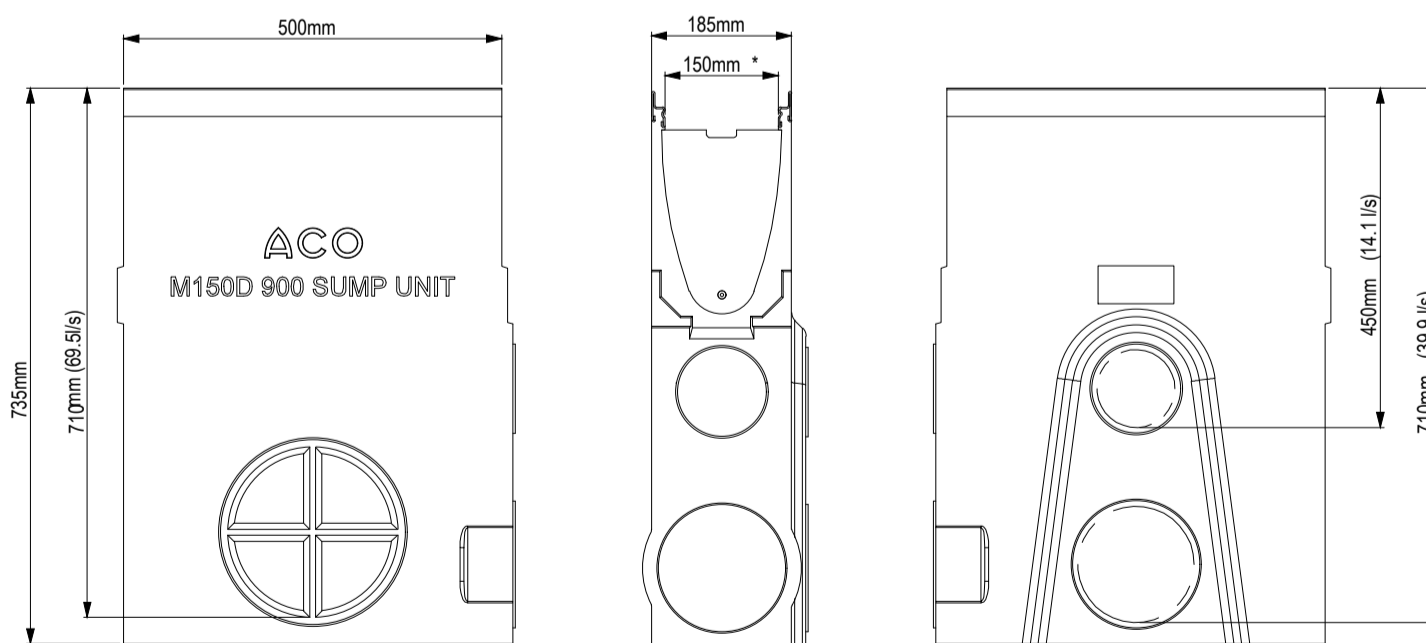

MULTIDRAIN UNIVERSAL SUMP M150D & M150DS SCALE 1:10

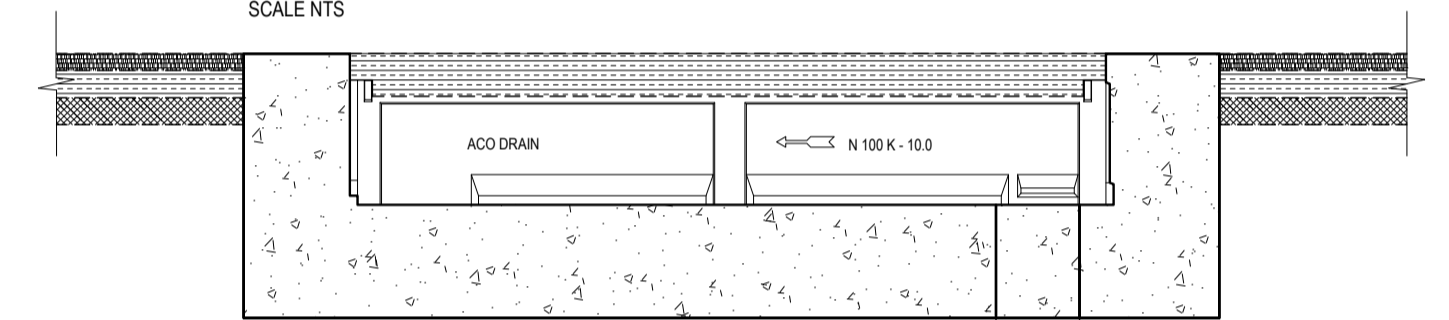

SECTION 1-1

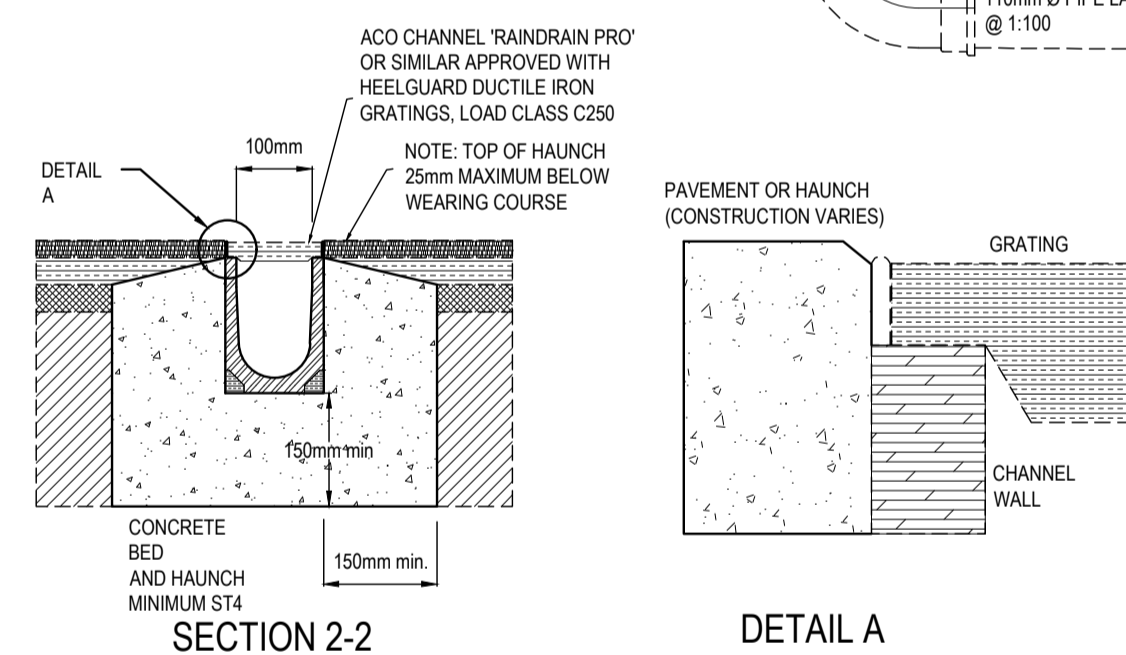

SECTION 2-2

DETAIL A

**ACO CHANNELS**

(SCALE 1:10)

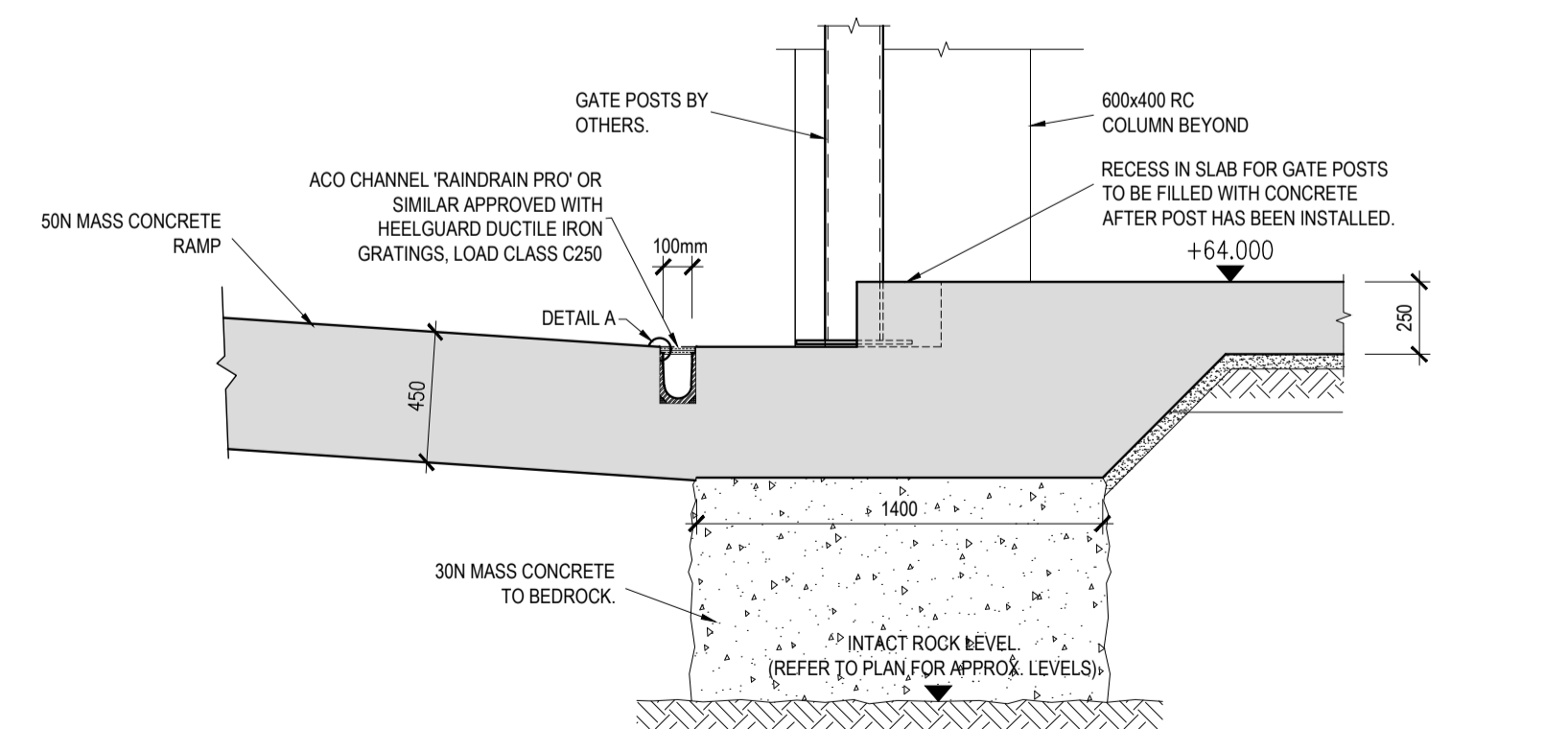

TYPICAL SECTION THROUGH ACO CHANNEL AT BOTTOM OF RAMP TO BASEMENT SCALE 1:25

© COPYRIGHT OF THIS DRAWING IS RESERVED BY DBFL CONSULTING ENGINEERS. NO PART SHALL BE REPRODUCED OR TRANSMITTED WITHOUT THEIR WRITTEN PERMISSION.

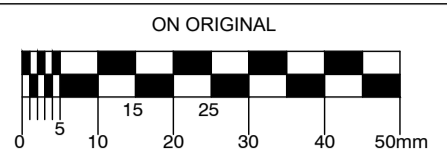

- NOTES:**
- ALL SEWERS SHALL BE PRESSURE TESTED PRIOR TO BACKFILLING
  - TYPE 1 GRANULAR MATERIAL:**  
BROKEN STONE OR GRAVEL TO PASS 10mm SIEVE AND BE RETAINED ON 5mm SIEVE.
  - TYPE 2 GRANULAR MATERIAL:**  
BROKEN STONE OR GRAVEL TO PASS 10mm - 25mm SIEVE, ACCORDING TO PIPE SIZE, (SEE TABLE) AND BE RETAINED ON 5mm SIEVE.
  - TYPE 3 SELECTED FILL:**  
UNIFORM READILY COMPACTED MATERIAL FREE FROM TREE ROOTS, VEGETABLE MATTER, BUILDING DEBRIS, AND FROZEN SOIL AND EXCLUDING CLAY LUMPS RETAINED ON A 75mm SIEVE AND STONES RETAINED ON A 37.5mm SIEVE.
  - RIGID PIPES SHALL MEAN CAST OR SPUN IRON, CONCRETE OR CLAY.
  - CONCRETE SURROUND REQUIRED TO ALL MANHOLE RINGS FROM 3.0m BELOW FINISHED GROUND LEVEL.
  - ALL LADDERS, RUNGS, SAFETY CHAINS etc SHALL BE HOT DIPPED GALVANISED TO BS 729 OR EQUIVALENT

P2	22-11-21	FOR SHD APPLICATION	JVS	BK
P1	03-12-19	FOR ASP APPLICATION	JVS	BK
REV	DATE	DESCRIPTION	BY	CHKD

**CONSTRUCTION**

DESIGNED	SPB	PREPARED	JVS
DATE	OCT 2019	CHECKED	BK

**DBFL** Dublin Office Ormond House, Upper Ormond Quay, Dublin 7, Ireland. PHONE +353 1 400 4000 FAX +353 1 400 4050

WATERFORD OFFICE Unit 2, The Chandery, 1-2 O'Connell Street, Waterford, Ireland. PHONE +353 51 309 500 FAX +353 51 844 913

DBFL Consulting Engineers email: info@dbfl.ie site: www.dbfl.ie

PROJECT  
**PROPOSED DEVELOPMENT AT CORNELSCOURT**

DRG. TITLE  
**TYPICAL DRAINAGE CONSTRUCTION DETAILS SHEET 4**

CLIENT  
**CORNEL LIVING LIMITED**

SCALE	AS SHOWN @A1	FILE REF.	180208-DBFL-XX-XX-DR-C-3013
DRG. NO.	180208-DBFL-XX-XX-DR-C-3013		P2